

DOUBLE RACK LIFTER

ES Doble Cremallera DE Zweifach Zahnstangen-System
IT Doppia Cremagliera PT Duplo Rack FR Double Cremaillere

● Cad Insertion Point

DR

Patented

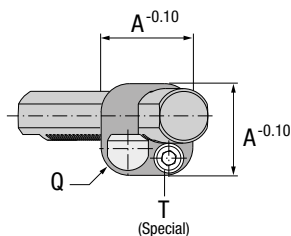
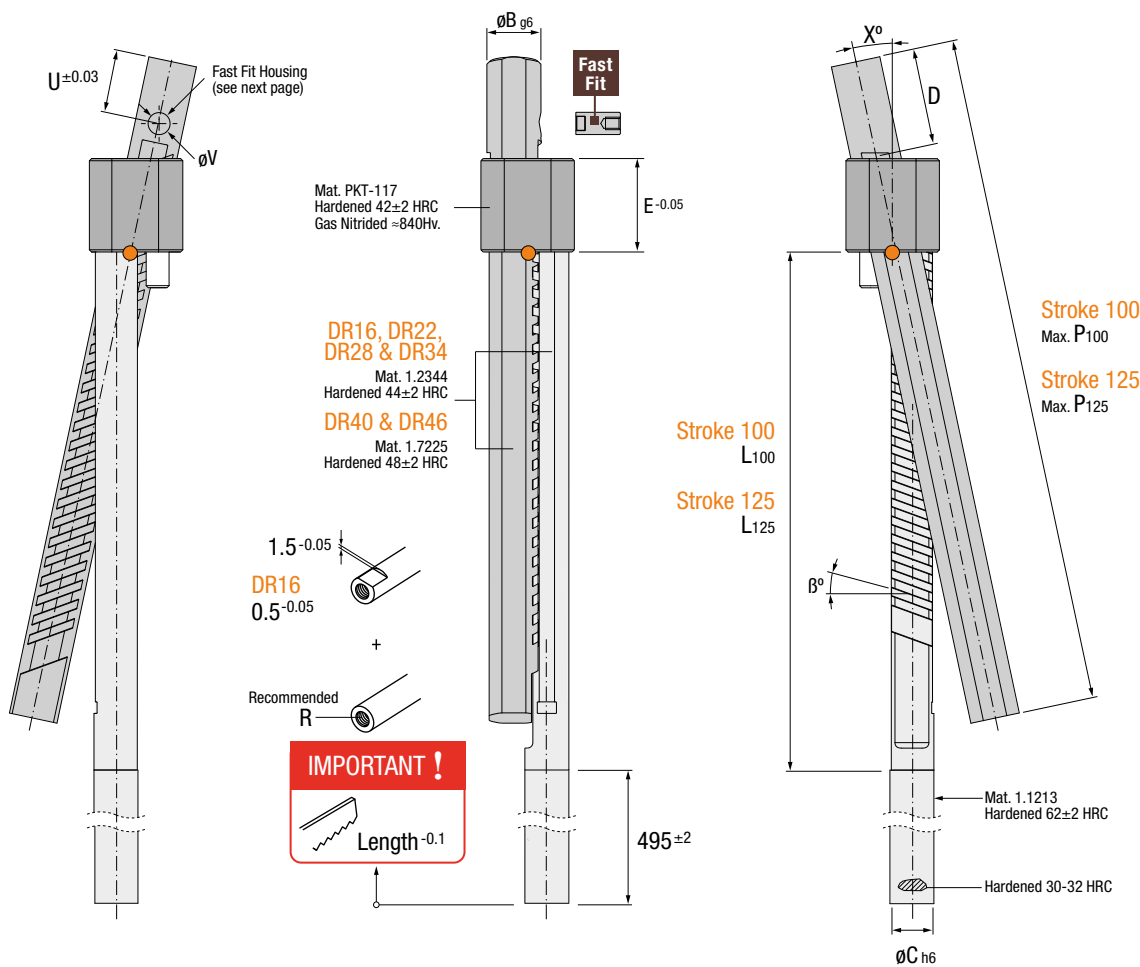

IMPORTANT !
Mirror Part.
Pieza Simétrica.
Symmetrisches Teil.
Versione a Specchio.
Peça em Espelho.
Pièce en Miroir.

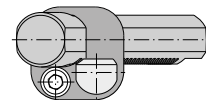

Stroke 100	Stroke 125	X°		A	B	C	D	E	L100	P100	L125	P125	Q	R	T	U	V	Stroke 100-S	Stroke 125-S		
DR.16100L-x	-	8	12	16	-	16	9	8	20	20	142	178	-	-	4	M5	M5	10	6	DR.16100L-x-S	-
DR.22100L-x	DR.22125L-x	8	12	16	20	22	12	12	30	22	148	202	202	261	6.5	M6	M6	17	8	DR.22100L-x-S	DR.22125L-x-S
DR.28100L-x	DR.28125L-x	8	12	16	20	28	16	14	36	28	152.5	214	194.5	266	8.5	M8	M8	23	8	DR.28100L-x-S	DR.28125L-x-S
DR.34100L-x	DR.34125L-x	8	12	16	20	34	20	16	36	34	160.5	227	188.5	264	10.5	M8	M8	23	8	DR.34100L-x-S	DR.34125L-x-S
DR.40100L-x	DR.40125L-x	8	12	16	20	40	22	20	36	40	170	244	204	284	10.5	M10	M10	20	10	DR.40100L-x-S	DR.40125L-x-S
DR.46100L-x	DR.46125L-x	8	12	16	20	46	24	24	42	46	175	258	201	289	10.5	M10	M12	26	10	DR.46100L-x-S	DR.46125L-x-S

IMPORTANT !

Replace the **X** in the reference with the required X° dimension (8°, 12°, 16° or 20°) and indicate the required β°.
Sustituir la **X** de la referencia por la cota X° deseada (8°, 12°, 16° o 20°), e indique el ángulo β° requerido.
Ersetzen Sie das **X** der Referenz durch den gewünschten X° Winkel (8°, 12°, 16° oder 20°). Geben Sie den benötigten β° Winkel an.
Sostituire la **X** del codice con l'angolo X° desiderato (8°, 12°, 16° o 20°) e indichiate la β° richiesta.
Substituir o **X** da referencia pela cota X° desejada (8°, 12°, 16° o 20°), e indique o angulo β° pretendido.
Remplacez la valeur **X** par la valeur angulaire X° désirée (8°, 12°, 16° ou 20°). Ensuite indiquez l'angle β° correspondant.

INSTALLATION GUIDELINES

ES Consejos de Instalación DE Richtlinien zur Installation
 IT Consigli di Installazione PT Instruções de Instalação FR Mode d'Installation

Core Housing
 Alojamiento Placa Punzón
 Einbaumaße DR Führung
 Sede nel Punzone
 Alojamento Bucha
 Logement dans l'empreinte

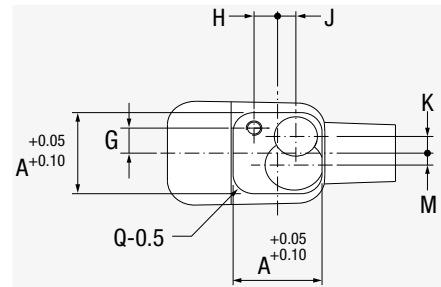
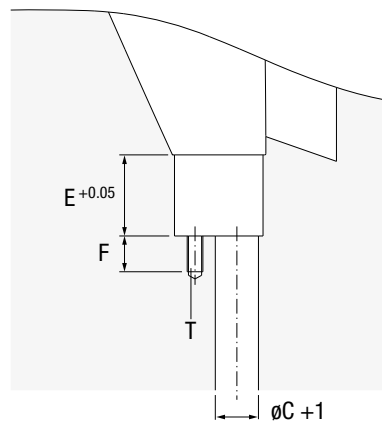
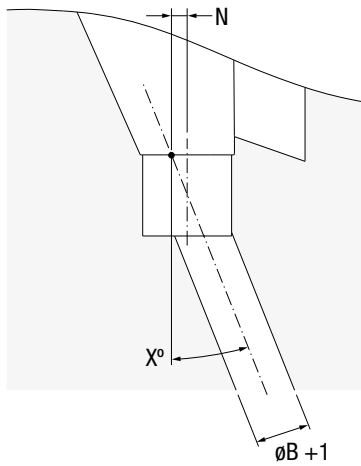

Stroke 100	Stroke 125	Stroke 200	F	G	H	J	K	M	N	S	T	W	Y	Z
DR.16100L-..	-	-	10	4.6	4.6	3	2.35	3	2.8	2.5	M5	6	9	M4
DR.22100L-..	DR.22125L-.. / KR.22125L-..	-	13	5.6	5.6	4.2	3.7	4.2	3.5	2.5	M6	8	12	M4
DR.28100L-..	DR.28125L-.. / KR.28125L-..	-	16	7.5	7.5	5	5.4	4.8	4.8	2.5	M8	8	13.5	M4
DR.34100L-..	DR.34125L-.. / KR.34125L-..	-	16	10.5	8	7	7	5	6	4	M8	8	16	M4
DR.40100L-..	DR.40125L-..	-	20	11	11	7	8	7	7	4	M10	10	20	M6
DR.46100L-..	DR.46125L-..	-	25	13	13	8	8	9	9	5	M12	10	24	M6
-	-	KR.58200L-..	28	15.5	15.5	10	12.2	11.2	10	5	M14	12	30	M6
-	-	KR.76200L-..	36	21	21	13	15.2	15.2	12	6	M18	12	36	M6

FAST FIT:
 Installation and Removal
 Instalación y Desinstalación
 Montage und Demontage
 Montaggio e Smontaggio
 Instalação e Desinstalação
 Montage et Démontage

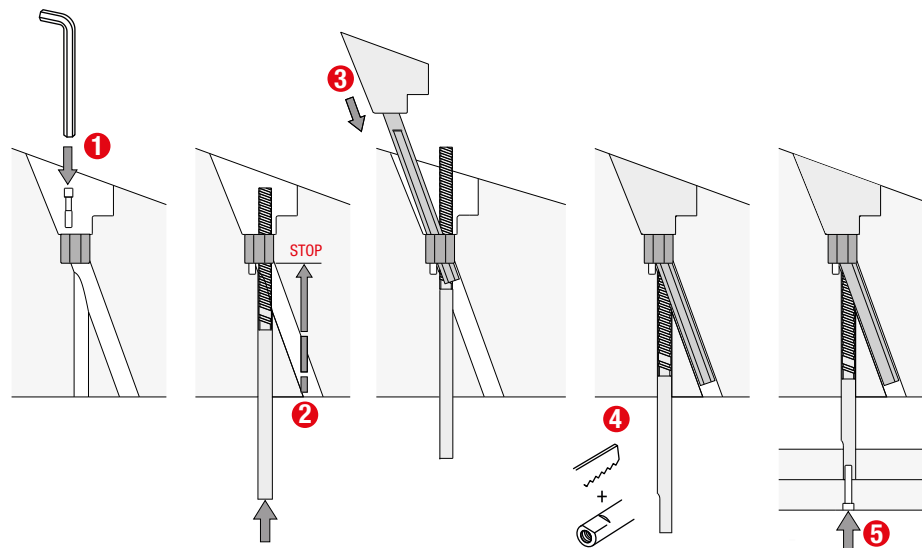
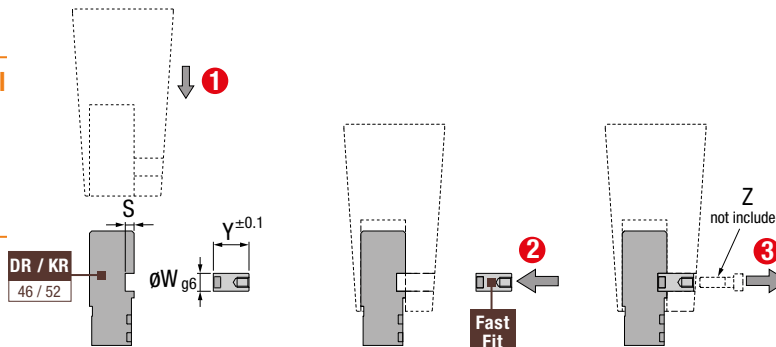

DR

UNDERCUTS



DOUBLE RACK SYSTEM

by CUMSA

COMPARE

Comparativa · Vergleich · Confronto · Comparativo · Comparatif

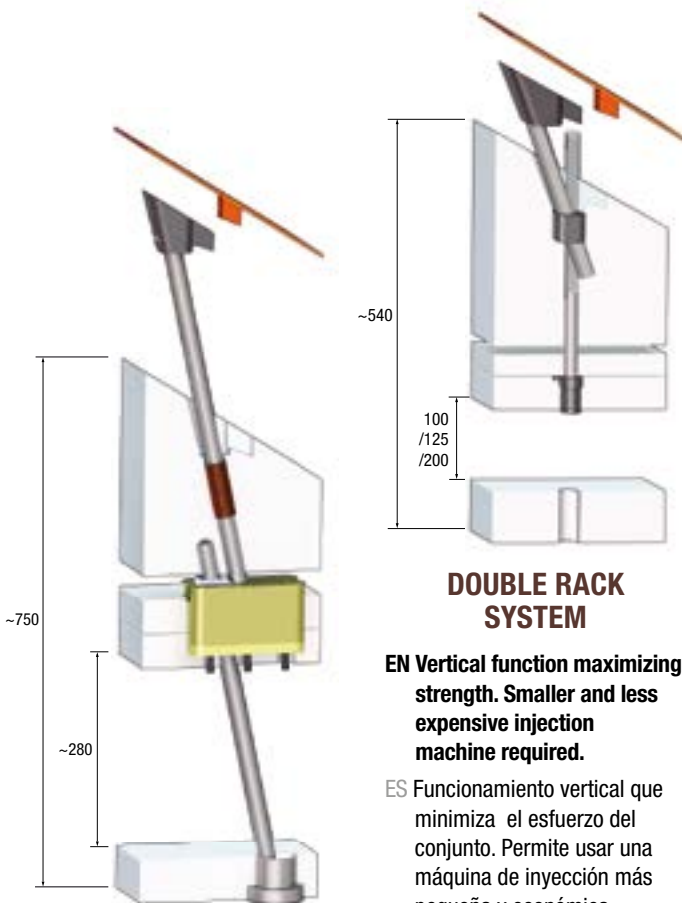

DOUBLE RACK SYSTEM

EN Vertical function maximizing strength. Smaller and less expensive injection machine required.

ES Funcionamiento vertical que minimiza el esfuerzo del conjunto. Permite usar una máquina de inyección más pequeña y económica.

DE Vertikale Funktion mit maximaler Kraft. Ein kleineres Werkzeug kann eventuell eine kleinere und günstigere Spritzgießmaschine benötigen.

IT Funzionamento verticale che minimizza lo sforzo. Permette di usare una macchina d'iniezione più piccola ed economica.

PT Funcionamento na vertical minimizando o esforço. Permite o uso de máquinas de injeção de menores dimensões e mais económicas.

FR Fonctionnement vertical réduisant les efforts. Permet de réduire la dimension de la presse d'injection et ainsi de réaliser des économies.

CONVENTIONAL SYSTEM

EN Eliminates the need for high-precision angled housings in the core plates.

ES Elimina los complicados taladros inclinados de alta precisión.

DE Es wird keine hochpräzise Schrägbohrung in der Formplatte benötigt.

IT Elimina le complicate lavorazioni inclinate ad alta precisione.

PT Elimina a necessidade de furos inclinados com precisão.

FR Termine les logements inclinés de haute précision.

Neutral angles ($\beta^\circ=0^\circ$)

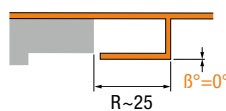

$S \geq R$

DR.xx100L-16
KR.xx200L-16
DR.xx125L-12
KR.xx125L-12
XR.xx100L-24

Positive Angles ($\beta^\circ>0^\circ$)

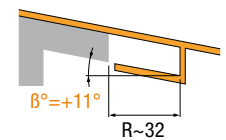

$S \geq R$

DR.xx100L-20
DR.xx125L-16
KR.xx125L-16
XR.xx100L-24

Negative Angles ($\beta^\circ<0^\circ$)

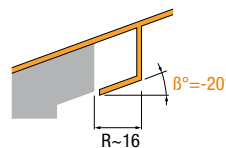

$S \geq R$

DR.xx100L-12
KR.xx200 L-12
DR.xx125L-8
KR.xx125L-8
XR.xx100L-24

IMPORTANT !

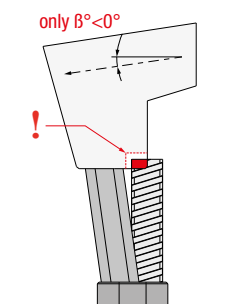

Stroke 100 (DR) Stroke 200 (KR) (Multiply S value x2)

β°	DR.xx100L-8	DR.xx100L-12		
	KR.xx200L-8	KR.xx200L-12		
	S (- β°)	S (+ β°)	S (- β°)	S (+ β°)
0	14.0	21.2		
1	14.0	14.0	21.1	21.3
2	13.9	14.1	21.1	21.4
3	13.9	14.1	21.0	21.5
4	13.9	14.1	20.9	21.5
5	13.8	14.2	20.8	21.6
6	13.8	14.2	20.7	21.7
7	13.8	14.3	20.7	21.8
8	13.7	14.3	20.6	21.9
9	13.7	14.3	20.5	22.0
10	13.7	14.4	20.4	22.0
11	13.6	14.4	20.4	22.1
12	13.6	14.4	20.3	22.2
13	13.6	14.5	20.2	22.3
14	13.5	14.5	20.1	22.4
15	13.5	14.6	20.1	22.5
16	13.5	14.6	20.0	22.6
17	13.4	14.6	19.9	22.7
18	13.4	14.7	19.8	22.8
19	13.4	14.7	19.8	22.9
20	13.3	14.8	19.7	23.0
21	13.3	14.8	19.6	23.1
22	13.2	14.9	19.5	23.2
23	13.2	14.9	19.4	23.3
24	13.2	14.9	19.4	23.4
25	13.1	15.0	19.3	23.5
26	13.1	15.0	19.2	23.7
27	13.1	15.1	19.1	23.8
28	13.0	15.1	19.0	23.9
29	13.0	15.2	19.0	24.0
30	12.9	15.2	18.9	24.2
31	12.9	15.3	18.8	
32	12.9	15.4	18.7	
33	12.8	15.4	18.6	
34	12.8	15.5	18.5	
35	12.7	15.5	18.5	
36	12.7		18.4	
37	12.7		18.3	
38	12.6		18.2	
39	12.6		18.1	
40	12.5		18.0	
41	12.5		17.9	
42	12.4		17.8	
43	12.4		17.7	
44	12.3		17.6	
45	12.3		17.5	

SELECTION TABLE: WHICH DR / KR DO I NEED?

ES TABLA DE SELECCIÓN: Qué DR / KR / XR necesito?

DE AUSWAHLTABELLE: Welcher DR / KR / XR ist am besten geeignet?

IT TABELLA PER SCELTA: Di quale DR / KR / XR ho bisogno?

PT TABELA DE SELEÇÃO: Qual é o DR / KR / XR que preciso?

FR TABLEAU DE CORRESPONDANCE: Quel est le DR / KR que j'ai besoin?



Stroke 100 (DR) Stroke 200 (KR) (Multiply S value x2)

	DR.xx100L-16		DR.xx100L-20	
	S (-β°)	S (+β°)	S (-β°)	S (+β°)
	28.6		36.4	
28.5	28.8	36.1	36.6	
28.3	28.9	35.9	36.8	
28.2	29.1	35.7	37.1	
28.1	29.2	35.4	37.3	
27.9	29.4	35.2	37.5	
27.8	29.5	35.0	37.8	
27.7	29.7	34.8	38.1	
27.5	29.8	34.6	38.3	
27.4	30.0	34.4	38.6	
27.2	30.2	34.2	38.8	
27.1	30.3	33.9	39.1	
27.0	30.5	33.7	39.4	
26.8	30.7	33.5	39.7	
26.7	30.8	33.3	40.0	
26.6	31.0	33.1	40.3	
26.5	31.2	32.9	40.6	
26.3	31.4	32.7	40.9	
26.2	31.6	32.5	41.2	
26.1	31.8	32.3	41.6	
25.9	32.0	32.1	41.9	
25.8	32.2	31.9		
25.6	32.4	31.7		
25.5	32.6	31.5		
25.4	32.8	31.3		
25.2	33.1	31.1		
25.1		30.9		
25.0		30.7		
24.8		30.4		
24.7		30.2		
24.6		30.0		
24.4		29.8		
24.3		29.6		
24.1		29.4		
24.0		29.2		
23.8		29.0		
23.7		28.7		
23.5		28.5		
23.4		28.3		
23.2		28.1		
23.1		27.8		
22.9		27.6		
22.7		27.4		
22.6		27.1		
22.4		26.9		
22.2		26.6		

Stroke 125 (DR / KR)

β°	DR.xx125L-8		DR.xx125L-12		DR.xx125L-16		DR.xx125L-20	
	KR.xx125L-8		KR.xx125L-12		KR.xx125L-16		KR.xx125L-20	
	S (-β°)	S (+β°)	S (-β°)	S (+β°)	S (-β°)	S (+β°)	S (-β°)	S (+β°)
0	17.5		26.5		35.8		45.4	
1	17.5	17.6	26.4	26.6	35.6	36.0	45.2	45.7
2	17.4	17.6	26.3	26.7	35.4	36.2	44.9	46.0
3	17.4	17.6	26.2	26.8	35.3	36.3	44.6	46.3
4	17.3	17.7	26.1	26.9	35.1	36.5	44.3	46.6
5	17.3	17.7	26.0	27.0	34.9	36.7	44.0	46.9
6	17.3	17.8	25.9	27.1	34.7	36.9	43.8	47.3
7	17.2	17.8	25.8	27.2	34.6	37.1	43.5	47.6
8	17.2	17.9	25.7	27.3	34.4	37.3	43.2	47.9
9	17.1	17.9	25.7	27.4	34.2	37.5	43.0	48.2
10	17.1	18.0	25.6	27.6	34.1	37.7	42.7	48.6
11	17.1	18.0	25.5	27.7	33.9	37.9	42.4	48.9
12	17.0	18.1	25.4	27.8	33.7	38.1	42.2	49.3
13	17.0	18.1	25.3	27.9	33.6	38.3	41.9	49.6
14	16.9	18.2	25.2	28.0	33.4	38.6	41.7	50.0
15	16.9	18.2	25.1	28.1	33.2	38.8	41.4	50.4
16	16.8	18.3	25.0	28.2	33.1	39.0	41.1	50.7
17	16.8	18.3	24.9	28.4	32.9	39.2	40.9	51.1
18	16.8	18.4	24.8	28.5	32.7	39.5	40.6	51.5
19	16.7	18.4	24.7	28.6	32.6	39.7	40.4	52.0
20	16.7	18.5	24.6	28.7	32.4	40.0	40.1	52.4
21	16.6	18.5	24.5	28.9	32.2	40.2	39.9	
22	16.6	18.6	24.4	29.0	32.1	40.5	39.6	
23	16.5	18.6	24.3	29.2	31.9	40.8	39.4	
24	16.5	18.7	24.2	29.3	31.7	41.0	39.1	
25	16.4	18.7	24.1	29.4	31.6	41.3	38.8	
26	16.4	18.8	24.0	29.6	31.4		38.6	
27	16.3	18.9	23.9	29.7	31.2		38.3	
28	16.3	18.9	23.8	29.9	31.1		38.1	
29	16.2	19.0	23.7	30.1	30.9		37.8	
30	16.2	19.1	23.6	30.2	30.7		37.5	
31	16.1	19.1	23.5		30.5		37.3	
32	16.1	19.2	23.4		30.3		37.0	
33	16.0	19.3	23.3		30.2		36.7	
34	16.0	19.4	23.2		30.0		36.5	
35	15.9	19.4	23.1		29.8		36.2	
36	15.9		23.0		29.6		35.9	
37	15.8		22.9		29.4		35.7	
38	15.8		22.7		29.2		35.4	
39	15.7		22.6		29.0		35.1	
40	15.7		22.5		28.8		34.8	
41	15.6		22.4		28.6		34.5	
42	15.5		22.3		28.4		34.2	
43	15.5		22.1		28.2		33.9	
44	15.4		22.0		28.0		33.6	
45	15.4		21.9		27.8		33.3	

Stroke 100 (XR)

β°	XRxx100L-24		XRxx100L-28		XRxx100L-32		XRxx100L-36	
	S (-β°)	S (+β°)	S (-β°)	S (+β°)	S (-β°)	S (+β°)	S (-β°)	S (+β°)
0	44.5		53.2		62.5		72.7	
1	44.2	44.9	52.7	53.7	61.8	63.2	71.7	73.6
2	43.8	45.2	52.2	54.2	61.2	63.9	70.9	74.5
3	43.5	45.6	51.7	54.7	60.5	64.6	70.0	75.5
4	43.2	46.0	51.3	55.2	59.9	65.3	69.1	76.5
5	42.9	46.3	50.8	55.8	59.2	66.1	68.3	77.6
6	42.5	46.7	50.4	56.3	58.6	66.9	67.5	78.7
7	42.2	47.1	49.9	56.9	58.0	67.7	66.7	79.8
8	41.9	47.5	49.5	57.5	57.4	68.5	65.9	
9	41.6	47.9	49.0	58.1	56.9	69.4	65.2	
10	41.3	48.3	48.6	58.7	56.3	70.2	64.4	
11	41.0	48.7	48.2	59.3	55.7	71.1	63.7	
12	40.7	49.2	47.8	59.9	55.2		62.9	
13	40.4	49.6	47.4	60.6	54.6		62.2	
14	40.1	50.1	46.9	61.3	54.1		61.5	
15	39.8	50.6	46.5	62.0	53.5		60.8	
16	39.5	51.0	46.1		53.0		60.1	
17	39.2	51.5	45.7		52.5		59.4	
18	38.9	52.1	45.3		51.9		58.8	
19	38.6	52.6	44.9		51.4		58.1	
20	38.3		44.5		50.9		57.5	
21	38.0		44.2		50.4		56.8	
22	37.7		43.8		49.9		56.2	
23	37.4		43.4		49.4		55.5	
24	37.2		43.0		48.9		54.9	
25	36.9		42.6		48.4		54.3	
26	36.6		42.2		47.9		53.6	
27	36.3		41.8		47.4		53.0	
28	36.0		41.5		46.9		52.4	
29	35.7		41.1		46.4		51.8	
30	35.4		40.7		45.9		51.2	
31	35.1		40.3		45.4		50.6	
32	34.8		39.9		44.9		50.0	
33	34.5		39.5		44.4		49.4	
34	34.2		39.1		44.0		48.8	
35	33.9		38.7		43.5		48.2	
36	33.6		38.4		43.0		47.6	
37	33.3		38.0		42.5		46.9	
38	33.0		37.6		42.0		46.3	
39	32.7		37.2		41.5		45.7	
40	32.4		36.8		41.0		45.1	
41	32.1		36.4		40.5		44.5	
42	31.8		36.0		40.0		43.9	
43	31.5		35.5		39.5		43.3	
44	31.1		35.1		39.0		42.7	
45	30.8		34.7		38.5		42.1	

Special β° angles possible under request
ES Posibilidad de ángulos β° especiales DE Sonderwinkel auf Anfrage möglich (β°) IT E' possibile avere angolazioni β° speciali su richiesta PT Possibilidade de ângulos β° especiais FR Possibilité de réaliser des angles β° spéciaux.